

Product and Installation Guide



Gas Detection System

- ◇ Gas detection from 1-32 detectors
- ◇ Peak and time weighted alarm levels
- ◇ Multiple relay options for BMS or remote signalling
- ◇ Status and alarm logging
- ◇ Highly adaptable
- ◇ Battery backup available
- ◇ 10-Year panel warranty
- ◇ Service contracts available including detector exchange programme

Have a question or need some help?

0161 233 0600

medem.co.uk
enquiries@medem.co.uk

The Pro-Elite gas detection system has been designed to be as flexible as possible.

Whether it's a simple installation requiring just one detector or a large distributed system with a mix of gas detector types, alarm settings and remote indications.



Pro-Elite Main Panel

The Pro-elite is a programmable, gas detection system capable of accepting up to 32 detectors.

The system will be preconfigured before supply but still require fully commissioning by Medem engineers before use.

Description

The system comprises of a main control panel to which up to 32 detectors of various types can be connected. All the alarm levels, types and timings are programmable within the system and these will be required when ordering and then confirmed/recorded during the commissioning phase.

Relays (BMS)

There are four potential free relay contacts available within the main panel to indicate "High & low "alarms, "Communication fault" (i.e. lost of comm's to a detector) and "Power failure".

Expanded System

Should further relay indications be required the system can be expanded with additional "Relay" Panels

You can connect up to four relay panels to the system each capable of indicating the status of individual detectors.



Pro-Elite

System Overview

— Low voltage

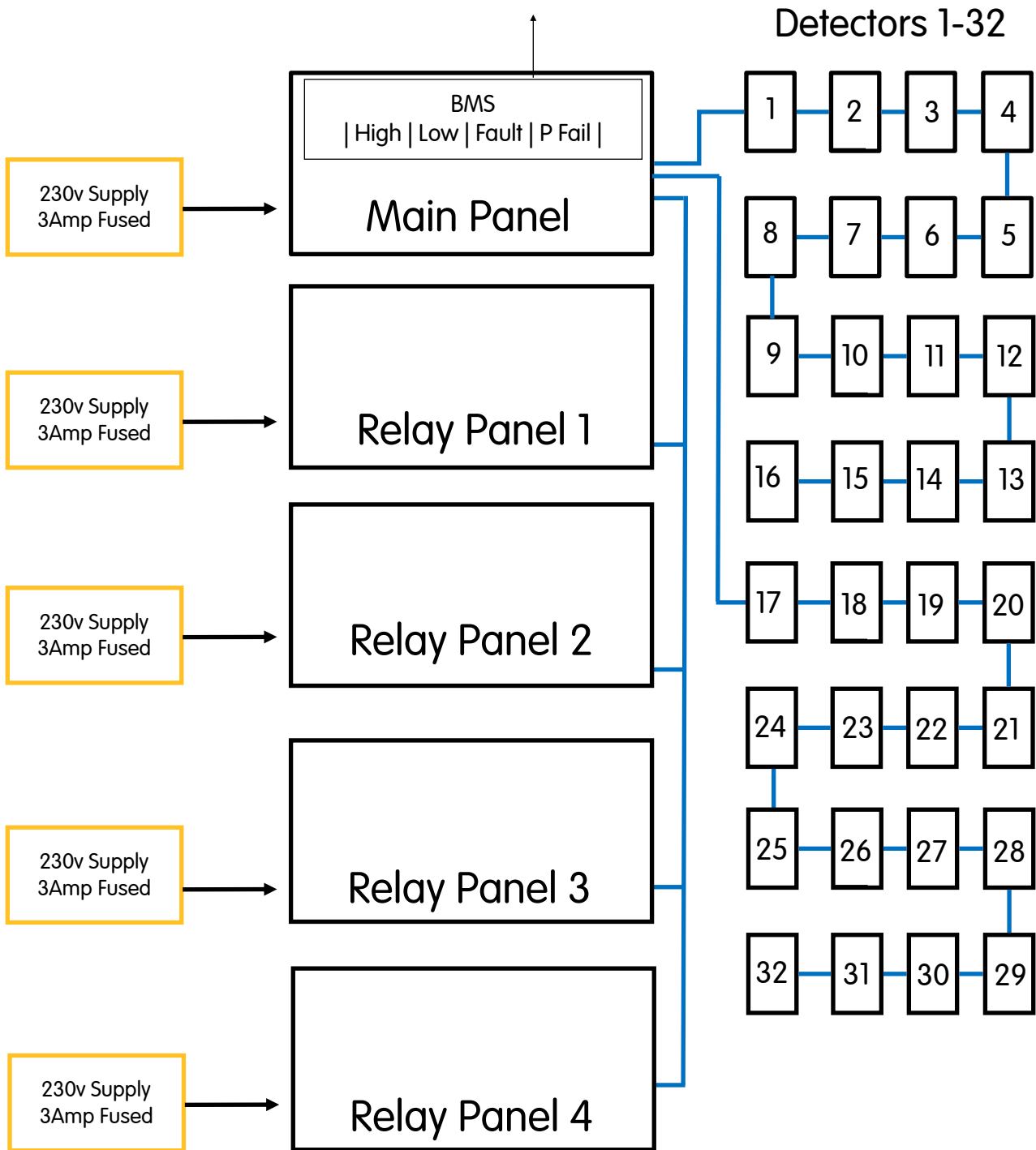

All Detectors, and relay panels require a four core screened Belden type security cable or 600v rated BMS cable (max cable length of 100meters.) for connection to the Pro-Elite .which must be ground at one end.

Warranty will be void if Fire Protection Cable or cable over 1mm dia. is used on the SELV side.

Detector Programmable Alarms Levels & Types

Each individual detector can have its own alarm levels and alarm type set.

The alarm levels for each individual detector are programmable at the main panel during setup/commissioning to any value within that given detector types sensor range.

Detectors can also be set to a "Peak" alarm (P) and (or) up to three different "Time Weighted Average" (TWA) alarms.

All detectors are set to their default values unless otherwise requested and a printed record of all detectors alarm levels, types and timings will be provided with the commissioning report and kept on record by Medem (UK) Ltd.

These setting are only adjustable by Medem engineers.

Example:

Det 1 : Carbon Monoxide
Peak: 300 PPM
TWA 1: 100PPM over 1 minutes
TWA 2: 80 PPM over 10 minutes
TWA 3: 30 PPM over eight hours
(Max time period of 24 hours)

Det 2 :Carbon Monoxide
Peak: 100 PPM

Det 3 : Methane
Peak: 40%
TWA 1: 20% over 5 minutes

An example list of currently available detectors and setting is on the back page.

We are adding new detector types to the range all the time, if you require something not listed please check the website or call us for an updated listing.

Safe zone, ATEX and aspirated options are available.

NOTE:

You must perform your own risk assessment to ensure alarms are set to appropriate levels for your application.

HSE Sheet EH40/2005 and the risk assessment process available on the HSE website may be used as a guide to assess your risk.

Latching/Non-latching Alarm State

Each detector can be set to latch on alarm or auto-reset as the detected level drops below the alarm level.

The time to latch can also be set for each detector for Peak Alarms from 01 to 59 seconds.

TWA alarms latch immediately once the time period at the given alarm level has been reached.

Detector Calibration and Servicing

All detectors will be checked and calibrated where required during the commissioning by the Medem engineer.

All detectors will require servicing and calibration with frequency determined by sensor type or application.

Medem engineers will be in contact to schedule a convenient time to carry this out .

A copy of the report will be provided to site and placed on record with Medem (UK) Ltd.

System Status and Detector Logging

System status interaction (system access, setting changes etc) are recorded and available to review on screen.

In addition a Medem engineer can download a 90 history of all detector readings, these can be plotted on to a graph and displayed as levels over time.

This can be extremely useful in understanding and diagnosing issues caused by environmental factors.

Relay Panels

Optional relay panels can be connected to the main panel.

Each relay panel has eight programmable relays. With these the status of individual detectors can be indicated as required.

Depending on the number of detectors and relay panels connected, each detector could have one relay set to indicate status (either high, low or fault), or could have multiple relays set to indicate multiple conditions. There is also a "double knock" relay to indicate if any two detectors on this panel (main or extender) enter a high alarm state.

Each Relay Panel has eight programmable relays and one "double knock" relay.

Example:

Relay 1 = Det 1, High Alarm

Relay 2 = Det 2, High Alarm

Relay 3 = Det 3, High Alarm

Relay 4 = Det 4, High Alarm

Relay 5 = Det 5, High Alarm

Relay 6 = Det 6, High Alarm

Relay 7 = Det 7, High Alarm

Relay 8 = Det 8, High Alarm

Or

Relay 1 Det 1 High Alarm

Relay 2 Det 1 Low Alarm

Relay 3 Det 1 Fault Alarm

Relay 9 = Double knock, changes state when any two or more detectors on its main reach high alarm.

Pro-Elite Main Panel Connections

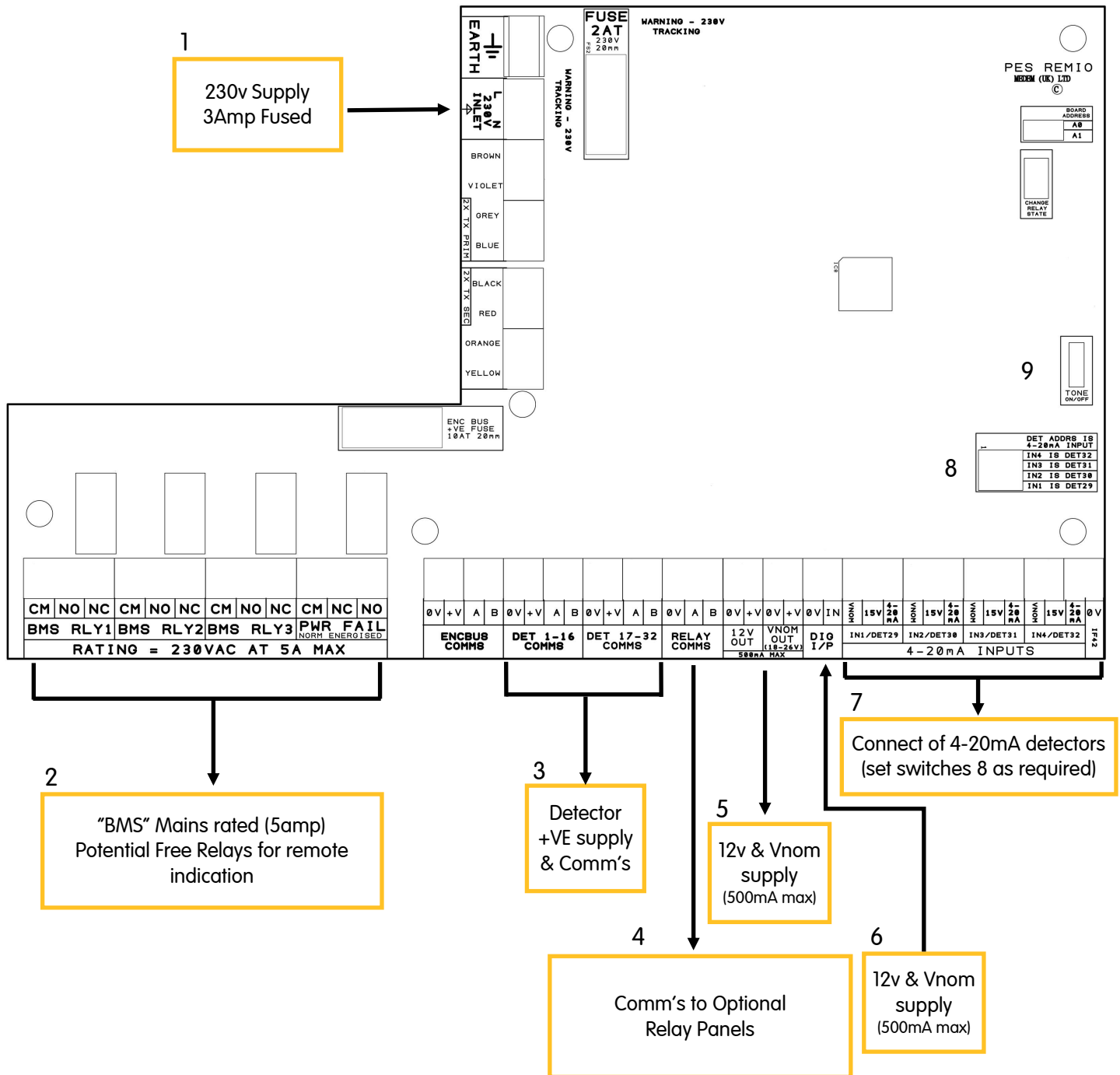

1. All Main, Extension and Relay panels require 230v supply via a 3amp fused spur.
2. BMS relays are mains rated for 5amp's, wiring will depend on connected equipment.
3. Detector supply and communications, are wired in parallel.
4. Extension panels are wired parallel.
5. Each main and extension panel can have its own relay panel.
6. 12v & Vnom power supply, for use with beacon/sounders
7. For connecting 4-20mA detector types to the system, set using switch 8
8. For enabling 4-20mA detector channels
9. Toner on/off

Pro-Elite Relay Panel Connections

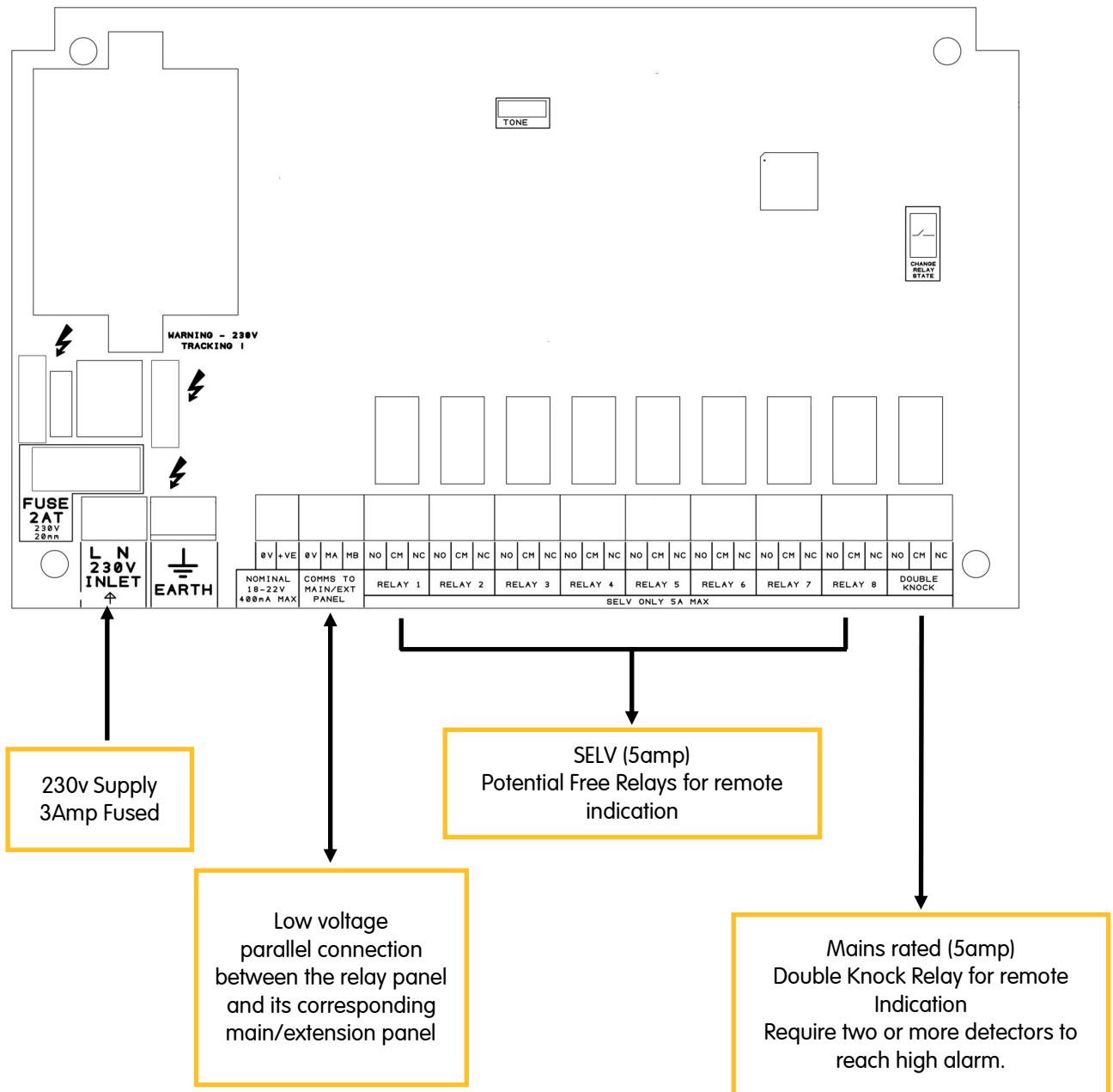

After wiring setup and configuration of the relay panels will be completed during commissioning.

Pro-Elite Detector Connections

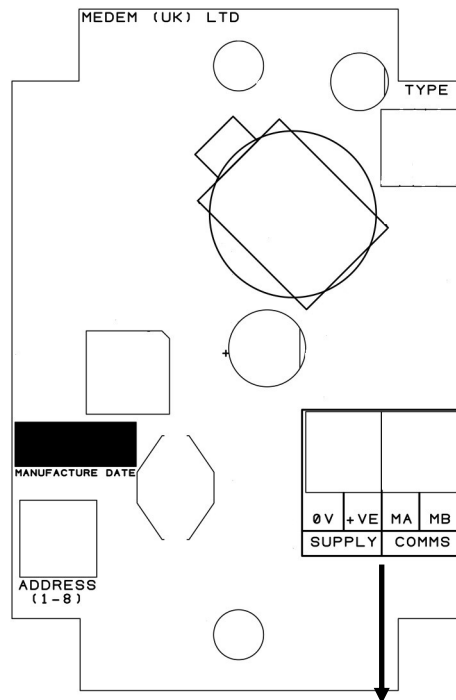

+VE supply & Comm's
From either the main panel or an extender.

Detectors are wired in parallel and can be connected to one another daisy chain

When connected you will receive one of the following LED indications

Unlit :	Not connected/Incorrectly wired.
Green Flashing Slow :	Detector not learnt.
Green Flashing Fast :	Invalid address.
Green Solid :	Detector learnt and ready.
Yellow Solid :	Low alarm.
Red Flashing Slow :	High alarm (unlatched).
Red Solid :	High alarm (latched).

All further setup will be completed during commissioning.

All Detectors, require a four core screened Belden type security cable or 600v rated BMS cable (max cable length of 100meters.) which must be ground at one end.

After installation is complete the system will require setup and commissioning to take place by a Medem engineer.

Pro-Elite Gas Detection Panels

Main Panel	Supports up to eight gas detectors with High, Low, Fault BMS indications Downloadable log file
Relay Panel	The main panel and each extension panel can have their own optional relay panel allowing indication of individual detector status

Pro-Elite Gas Detectors

Detector Types		Default Alarm levels	Sensor Range
Methane/Natural Gas	CH ₄	50,000 PPM (10%LEL)	0-100% LEL
Propane	C ₃ H ₈	21,000 PPM (10%LEL)	0-100% LEL
Carbon Monoxide	CO	100 PPM	1000 PPM
Carbon Dioxide	CO ₂	5000 PPM	9000 PPM
Oxygen – enrichment and depletion.	O ₂	-18 % or + 24%	
Ammonia	NH ₃	25 PPM	0-100 PPM
Hydrogen	H	20,000 PPM (2%vol)	0-100% LEL
Nitric Oxide	NO	25 PPM	0-250 PPM
Nitrogen Dioxide	NO ₂	5 PPM	0-30 PPM

We are adding new detector types to the range all the time, if you require something not listed contact us.

Safe zone, ATEX and aspirated options are available.

medem

Medem (UK) Ltd, Project House,
19 Dallimore Road, Roundthorn Industrial Estate,
Manchester, M23 9NX, +44 (0)161 233 0600

medem.co.uk
enquiries@medem.co.uk